

Keysight Technologies 5530 Dynamic Calibrator

Data Sheet



Introduction

5530 Dynamic Calibrator Requirements

Power Requirements

Laser Head:
100 – 240 Vac, 50/60 Hz
50W (during warmup), 33W (after warmup)

Calibrator Electronics (all +5V via USB):
E1735A 280 mA max
E1736A 120 mA (plus sensors)
E1737A 6 mA maximum, 0.3 mA typical
E1738A 6 mA maximum, 0.6 mA typical

System Requirements

Environmental
Operating Temperature: 0 – 40°C (32 – 104°F)
Optics temperature must be stabilized to $\pm 2^\circ\text{C}$
to achieve accuracy specifications.

PC Requirements Compatible with any portable computer with Windows XP, Windows Vista (32-bit), Windows 7 (32-/64-bit) or Windows 8 (32-/64-bit) and two USB 2.0 ports and a CD drive

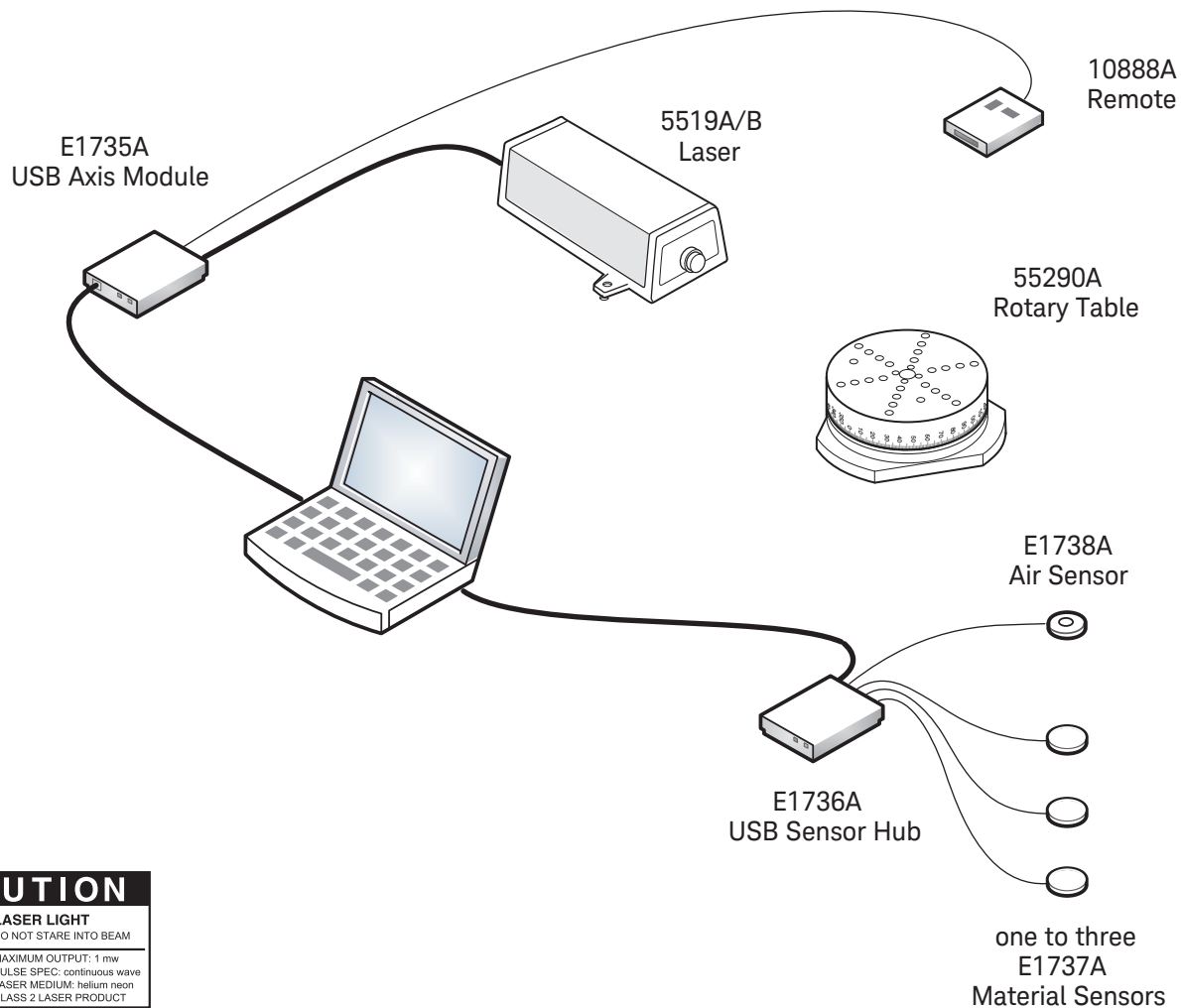

Specifications

Laser Characteristics

Type: Helium-Neon with automatically tuned Zeeman-split two-frequency output

Output Power: $\geq 180 \mu\text{W}$
($< 1 \text{ mW}$ per Class II Laser Product)

Safety Classification:
Class II Laser Product conforming to U.S. National CDRH Regulations 21CFR 1040.10 and 1040.11.

Warm-up Time: Less than 10 minutes
(4 minutes typical)

Vacuum Wavelength: 632.991354 nm

Wavelength Accuracy: $\pm 0.1 \text{ ppm}$
($\pm 0.02 \text{ ppm}$ of measured wavelength wavelength with factory calibration, Option A6J)

Wavelength Stability (typical):
short term (1 hour): $\pm 0.002 \text{ ppm}$
long term (lifetime): $\pm 0.02 \text{ ppm}$

Beam Diameter: 6 mm (0.24 in)

Beam Centerline Spacing:
11.0 mm (0.44 in) (input to output aperture)

Linear Distance, Diagonal, and Velocity Measurement Specifications

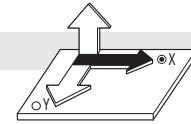

Measurement Range

Up to 40 m (130 ft) with Linear Optics;
Up to 80 m (260 ft) with Long Range Option

Linear Distance and Diagonal Measurement Accuracy

Temperature Range, °C [°F]	E1738A Air Sensor	In Vacuum†
0 – 40° [32° – 104°]	$\pm 0.4 \text{ ppm}$	$\pm 0.1 (\pm 0.02) \text{ ppm}$

† Vacuum accuracy is $\pm 0.02 \text{ ppm}$ if the laser head is calibrated to MIL-STD 45662A.

Velocity Measurement Accuracy

$$\left[\frac{2 \text{ mm/s}}{\text{Velocity}} + 0.01 \right] \% \text{ of displayed value}$$

Linear Distance and Diagonal Measurement Performance

OPTICS	RESOLUTION	MAXIMUM AXIS VELOCITY	
		5519A	5519B
Linear Optics (10766A)	1 nm (0.04 μin)	$\pm 0.7 \text{ m/s}$ ($\pm 28 \text{ in/s}$)	$\pm 1 \text{ m/s}$ ($\pm 40 \text{ in/s}$)
Plane Mirror Optics (10706A/B) *	0.5 nm (0.02 μin)	$\pm 0.35 \text{ m/s}$ ($\pm 14 \text{ in/s}$)	$\pm 0.5 \text{ m/s}$ ($\pm 20 \text{ in/s}$)
High Resolution Plane Mirror Optics (10716A)*†	0.25 nm (0.01 μin)	$\pm 0.18 \text{ m/s}$ ($\pm 7 \text{ in/s}$)	$\pm 0.25 \text{ m/s}$ ($\pm 10 \text{ in/s}$)

* Requires the 10724A Plane Mirror Reflector. Since alignment of these optics is much more sensitive than for linear optics, linear optics are recommended for general use.

† Aperture distance of 10716A is 12.7 mm, whereas 5519A is 11 mm.

Angular Measurement Specifications

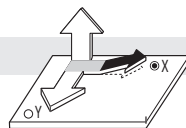

Angle Measurement Accuracy

$\pm 0.2\%$ of displayed value
 $\pm 0.05 \text{ arc-seconds}$ per meter of distance traveled by the linearly moving optic.

Maximum Distance Between Laser Head and Reflector

Up to 15 m (50 ft)

Angle Measurement Resolution

0.005 arc-seconds

Measurement Range

$\pm 10^\circ$ (rotated about base of optic)
 $\pm 20^\circ$ (rotated about center of optic)

Measurement Type

Pitch and yaw

Specifications

Angular Position Measurement Specifications (55290A Rotary Axis Kit)

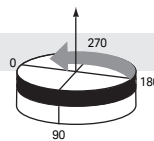

Measurement Type

Rotary and indexing tables or spindles

Indexing Mode (zero-reference measurement)

Accuracy: 0.5 sec band +0.2% of displayed reading

Index Step Size: 1°

Range: multiple rotations or partial arcs

Indexing Mode (Interferometer in fixture)

Maximum Lift: 15 mm (2 mm required for fixture)

Laser Measurement Mode

Accuracy: 0.2% of displayed reading. Accuracy can be improved to 0.5 sec by calibrating laser optics with the indexing table (55290A).

Range: $\pm 10^\circ$

Setup Requirements

Travel (using +2 mm, -1 mm machine axis, or manual from zero reference)

Flatness and Way Straightness Measurement Specifications¹

1. Values do not include effects of surface cleanliness or operator positioning repeatability.



Flatness Measurement Accuracy

$\pm 0.2\%$ of displayed value

± 0.05 arc-seconds per meter of distance traveled by the moving optic

Flatness Measurement Resolution (per step)

Footspacing Dimension	Resolution
50.8 mm (2 in)	0.03 micron (1.0 μin)
101.6 mm (4 in)	0.05 micron (2.0 μin)
152.4 mm (6 in)	0.08 micron (3.0 μin)

Way Straightness Accuracy

$\pm 0.2\%$ of displayed value

± 0.05 arc seconds per meter of distance traveled by the moving optics

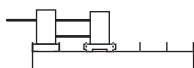

Flatness and Way Straightness Maximum Range

15m (50 ft)

Reference Plane Accuracy

The uncertainty of a surface plate flatness measurement is bounded by two parallel planes separated by the values below:

Metric Units Mode: $0.03 (M)^2 \mu\text{m}$

English Units Mode: $0.12 (F)^2 \mu\text{in}$

where:

M = length of the surface diagonal in meters

F = length of the surface diagonal in feet

Lateral Offset and Flatness Range

The combination of lateral offset and maximum flatness deviation must not displace the reflector more than ± 1.0 mm from the beam path in any direction.

Specifications

Straightness and Parallelism Measurement Specifications

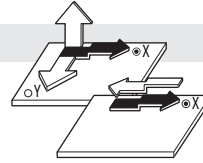

Straightness Measurement Accuracy¹

Overall Accuracy = Optical Reference Accuracy
+ Measurement Accuracy

¹ This is analogous to the traditional straightedge and indicator method of measuring straightness, where Optical Reference Accuracy corresponds to the straightedge accuracy, and Measurement Accuracy corresponds to the indicator accuracy.

Optical Reference Accuracy

Optical reference inaccuracy can be eliminated by using straightedge (mirror) reversal techniques.

Short Range Optics:

Metric units mode: $\pm 0.15 (M)^2 \mu\text{m}$

English units mode: $\pm 0.5 (F)^2 \mu\text{in}$

Long Range Optics:

Metric units mode: $\pm 0.015 (M)^2 \mu\text{m}$

English units mode: $\pm 0.05 (F)^2 \mu\text{in}$

where:

M = distance of travel of the moving optic in meters

F = distance of travel of the moving optic in feet

Straightness Measurement Range (Orthogonal to Axial Travel)

$\pm 1.5 \text{ mm}$ (0.060 in)

Axial Separation (Travel)

(distance between the interferometer and the reflector, typical, with proper alignment, 15 - 25°C):

Short Range Optics: 0.1 - 3m (4 - 120 in)

Long Range Optics: 1 - 30m (3 - 100 ft)

Measurement Accuracy²

Short Range Optics:

Temperature Range	Displayed Value	
	0 - 10 μm (0 - 400 μin)	10 - 1,500 μm (400 - 60,000 μin)
0 - 40°C	$\pm 3.5\%$	$\pm 1\% \pm 0.25 \mu\text{m}$ (10 μin)

Long Range Optics:

Temperature Range	Displayed Value	
	0 - 100 μm (0 - 4000 μin)	100 - 1,500 μm (4000 - 60,000 μin)
0 - 40°C	$\pm 5\%$	$\pm 2.5\% \pm 2.5 \mu\text{m}$ (100 μin)

² Measurement Accuracy specifications are not applicable to Timebase Straightness Measurements.

Straightness³ Measurement Resolution

Short Range	0.01 μm (0.4 μin)
Long Range	0.1 μm (4 μin)

³ Straightness Measurement Resolution specifications are not applicable to Timebase Straightness Measurements.

Squareness Measurement Accuracy

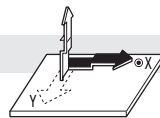

Short Range Optics:

Metric Units Mode:

$\pm(1.0 + 0.1 M) \text{ arc-seconds} \pm 0.01 \theta$

English Unit Mode:

$\pm(1.0 + 0.03 F) \text{ arc-seconds} \pm 0.01 \theta$

where:

θ = calculated out-of-square angle in arc-seconds

M = distance of travel of the moving optic in meters

F = distance of travel of the moving optic in feet

Long Range Optics:

Metric Units Mode:

$\pm(1.0 + 0.01 M) \text{ arc-seconds} \pm 0.025 \theta$

English Units Mode:

$\pm(1.0 + 0.003 F) \text{ arc-seconds} \pm 0.025 \theta$

Specifications

Environmental Compensation¹ and A-quad-B Input

1. Compensation values may be manually entered by user via keyboard.

E1738A Air Sensor²

2. Refer to the E1738A Air Sensor Data Sheet, 5989-8456 for more specifications.

Wavelength of Light (WOL) in Air Compensation

The E1738A Air Sensor provides for the automatic display of pressure, temperature, relative humidity, and computed WOL.

Operating Range

Temperature: 0 – 40°C (32 – 104°F)
 Relative Humidity: 10% – 90%
 Absolute Pressure: 70 – 110 kPa (10 – 16 psia)

Heat Dissipation: 2 mW typical

Time Constant: 5 min typical (temperature)

Accuracy⁴

Temperature: $\pm 0.1^{\circ}\text{C}$ ($\pm 0.2^{\circ}\text{F}$)
 Relative Humidity: $\pm 5\%$
 Absolute Pressure: ± 50 Pa (± 0.008 psi)

4. 12 month calibration interval

E1737A Material Temperature Sensor³

3. Refer to the E1737A Material Sensor Data Sheet, 5989-8455 for more specifications.

Material Temperature Compensation

The E1737A Material Temperature Sensor provides for the automatic display of the temperature of the device under test. One to three sensors may be used.

Operating Range

Temperature: 0 – 40°C (32 – 104°F)
 Material Expansion Coefficient:
 range: –100.0 to +100.0 ppm per °C or °F,
 manually entered.

Heat Dissipation: 1 mW typical

Time Constant: 60s typical

Accuracy⁴

Temperature: $\pm 0.1^{\circ}\text{C}$ ($\pm 0.2^{\circ}\text{F}$)

4. 12 month calibration interval

Shared Sensor Characteristics

Maximum Compensation Update Rate

per 15s (combined WOL and material temperature compensation)

Cable Lengths:

E1739A–5m (16 ft)
 E1739B–10m (33 ft)
 E1739C–15m (49 ft)
 E1739D–25m (82 ft)

A-quad-B Input

Differential Input Threshold

$\pm 0.5\text{V}$ minimum, $\pm 7.0\text{V}$ maximum

Differential Input Impedance

100W

Input Rate

>2 ns edge-to-edge, or <10 MHz information rate

Example: at maximum speed, A and B both must be <2.5 MHz.

System Component Dimension and Weights

Keysight 5519A/B Laser Head

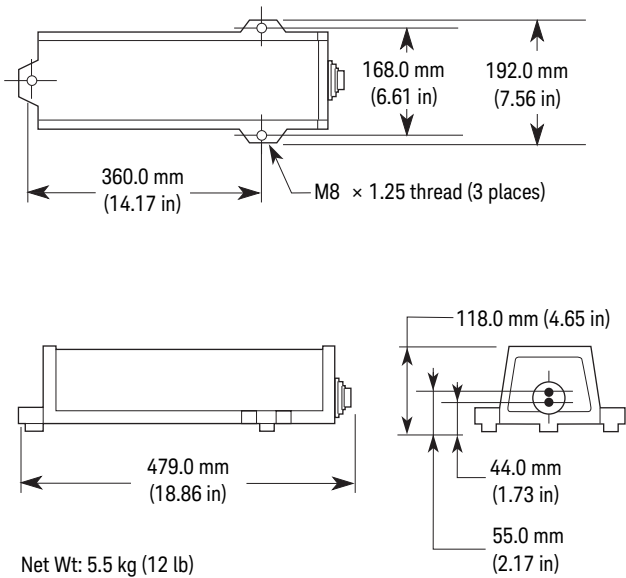

Keysight 10753B Laser Tripod

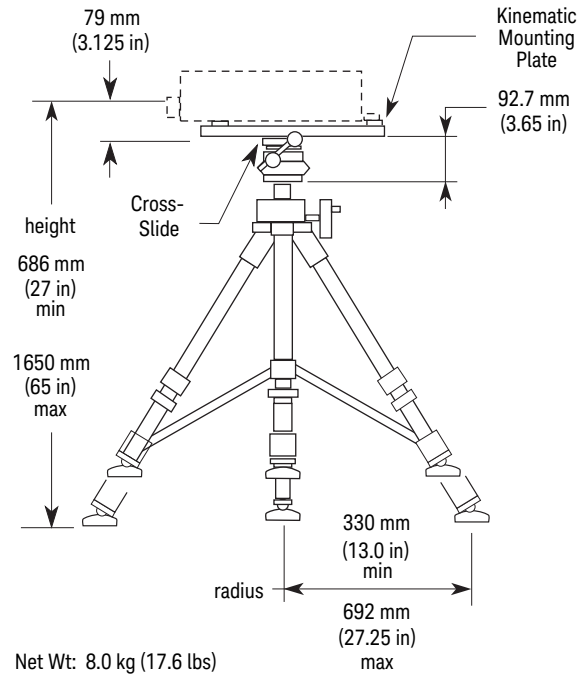

E1735A USB Axis Module

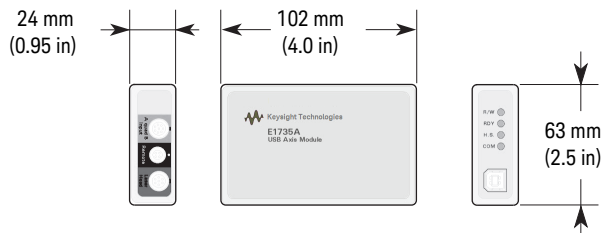

E1736A USB Sensor Hub

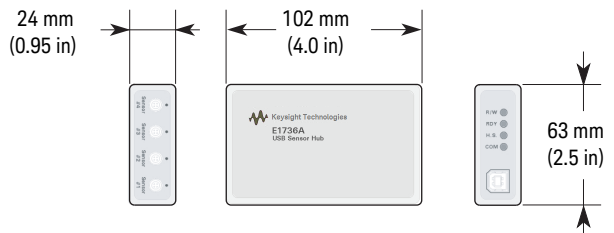

E1737A Material Sensor

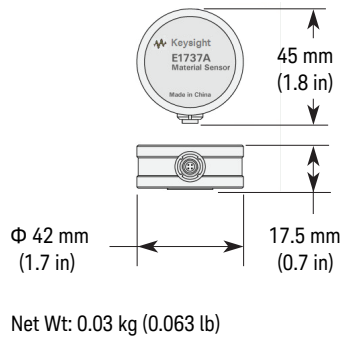

E1738A Air Sensor

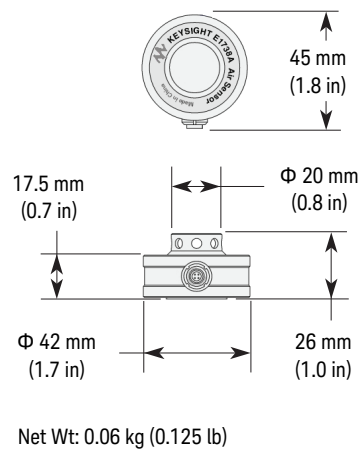

Optics and Accessories

Linear Optics

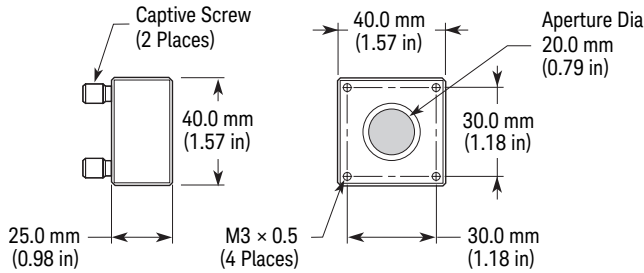

Keysight 10767A Linear Retroreflector
Net Wt: 224g (0.5 lb)

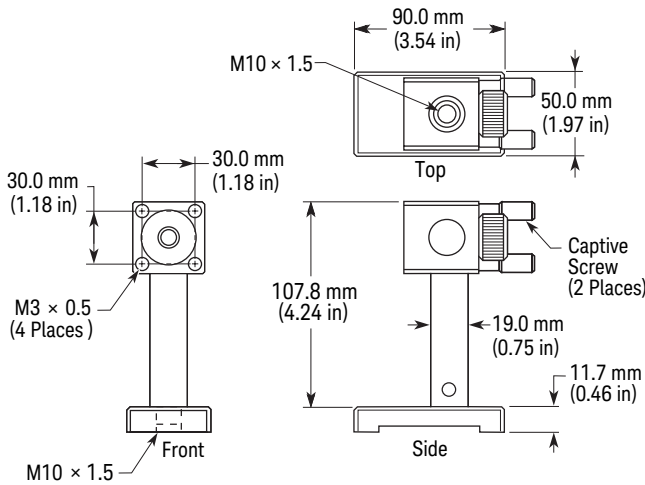

Keysight 10785A Height Adjuster/Post, 10784A Base

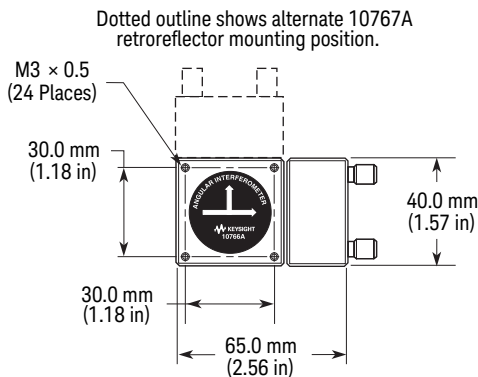

Keysight 10766A/10767A Interferometer Combination
Net Wt: 5.36g (1.2 lb)

Angular Optics

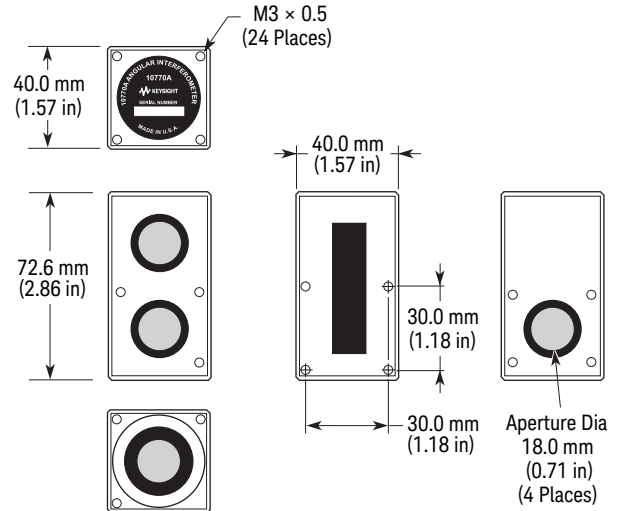

Keysight 10770A Angular Interferometer
Net Wt: 553g (1.3 lb)

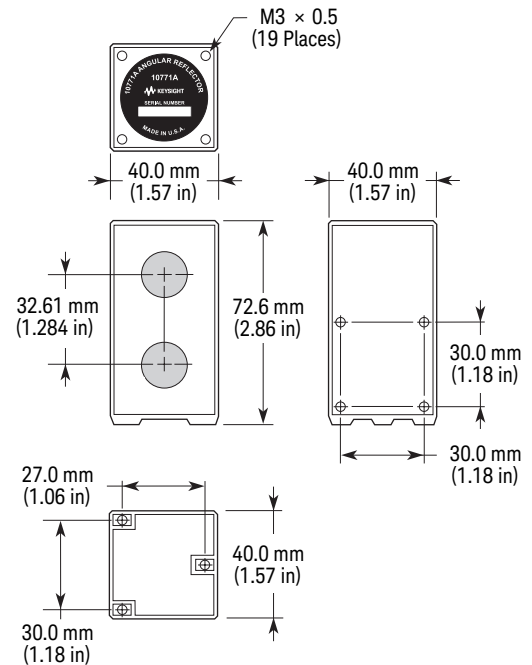

Keysight 10771A Angular Reflector
Net Wt: 650g (1.5 lb)

Optics and Accessories

Flatness Accessories

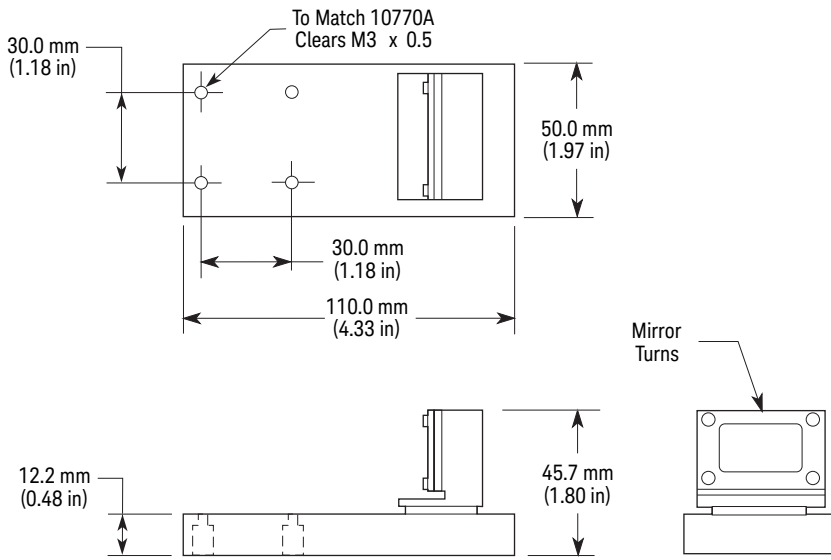

Keysight 10773A Flatness Mirror

Net Wt: 661g (1.5 lb)

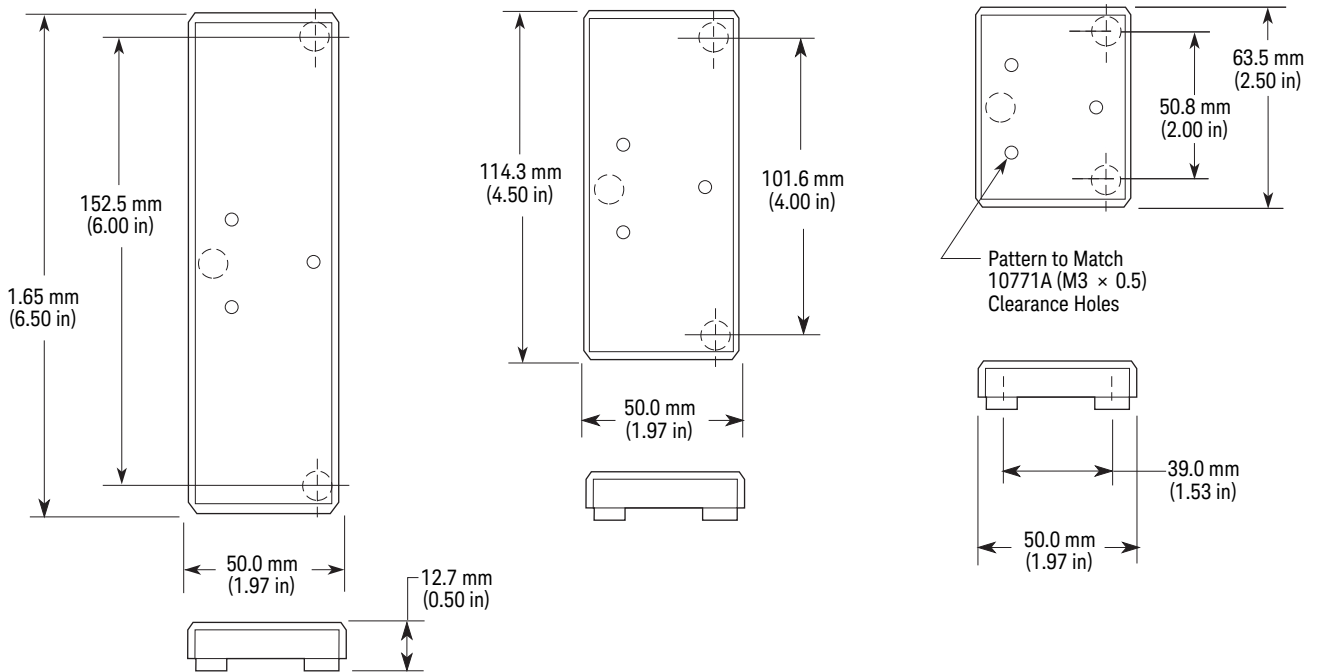

Keysight 10759A Foot Spacing Kit

Net Wt: 661g (1.5 lb)

Optics and Accessories

Straightness / Squareness Optics

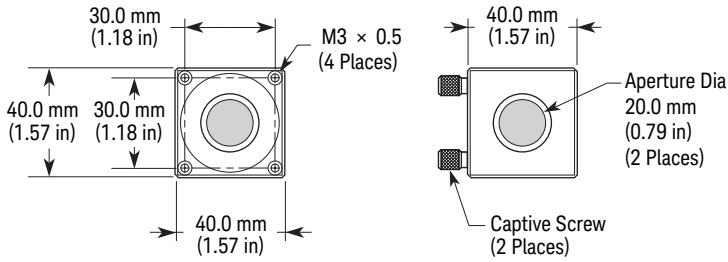

Keysight 10772A Tuning Mirror
 Net Wt: 510g (1.2 lb) w/Mount

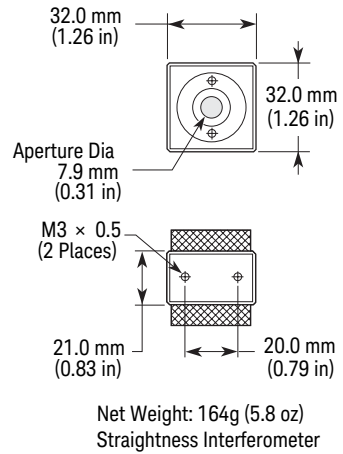
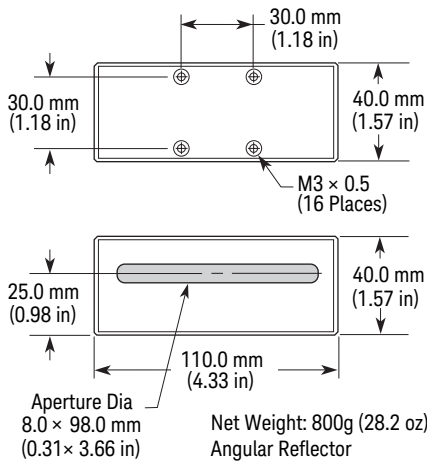

Keysight 10774A Short Range Straightness Optics / 10775A Long Range Straightness Optics

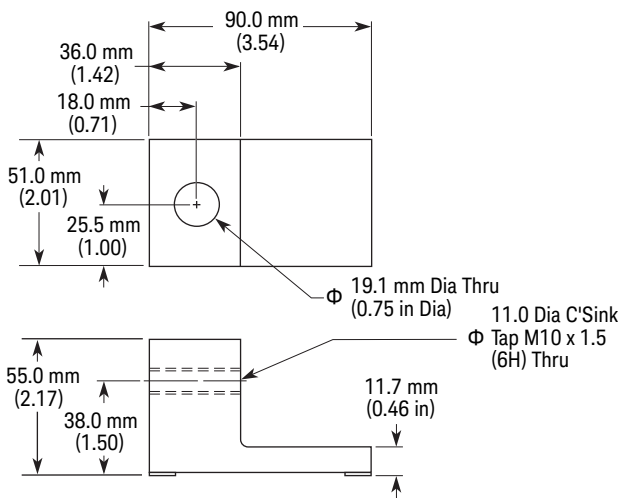

Keysight 10776A Straightness Mount

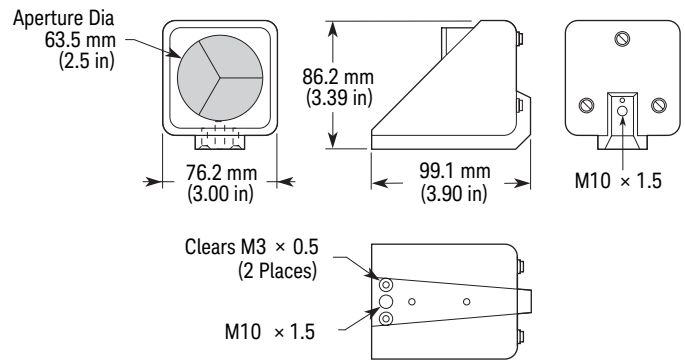

Keysight 10776-67001 Straightness Retroreflector
 Net Wt: 374g (0.82 lb)

Optics and Accessories

Straightness / Squareness Optics

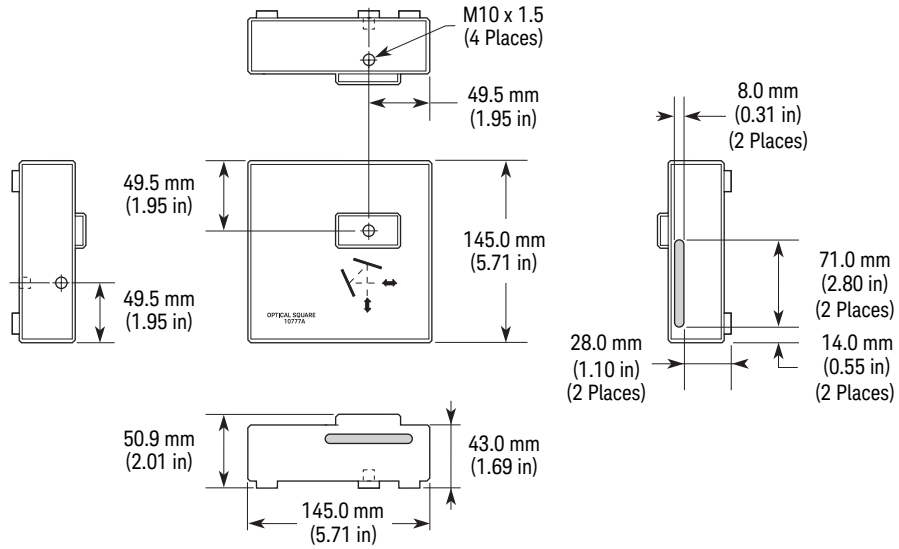

Keysight 10777A Optical Square

Net Wt: 4.0 kg (8.9 lb) w/Mount

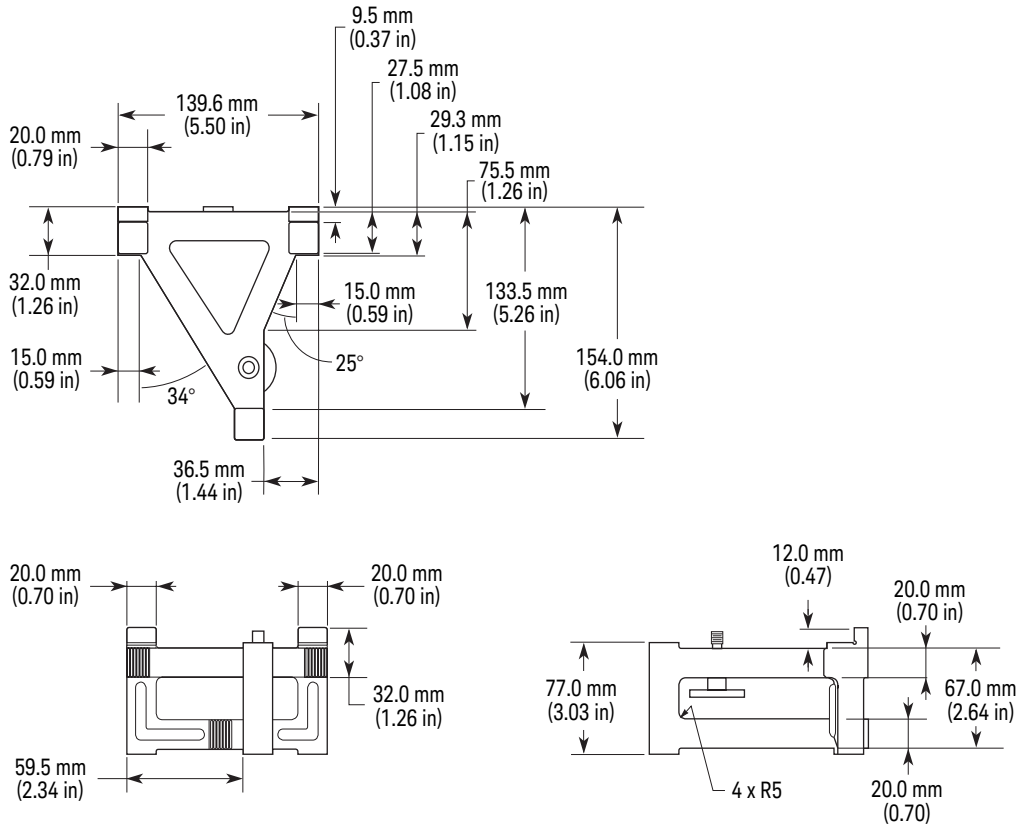

Keysight 10777-2007 Optical Square Base

Optics and Accessories

Straightness / Squareness Optics

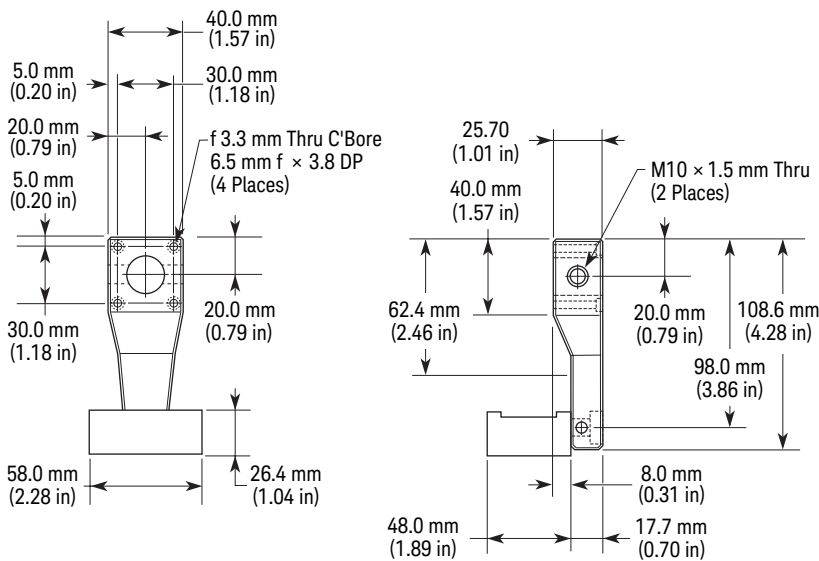
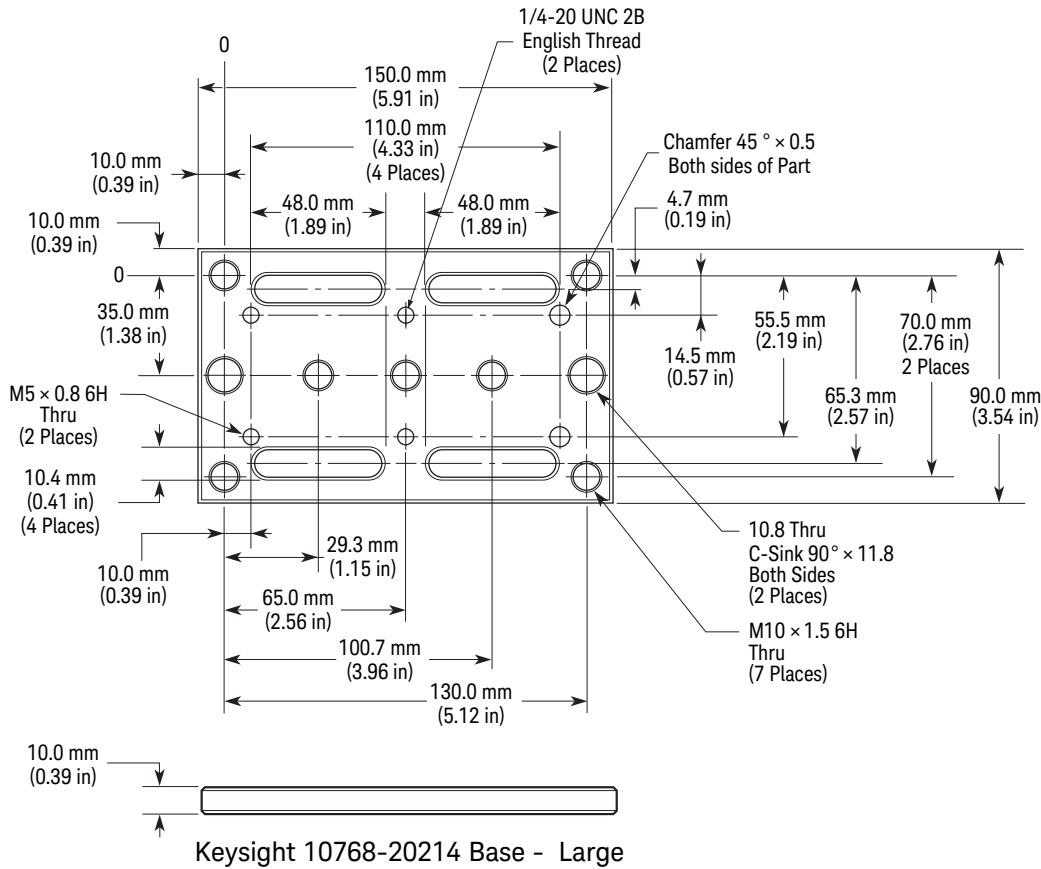

from Keysight 10768A/10769A Measurement Kit

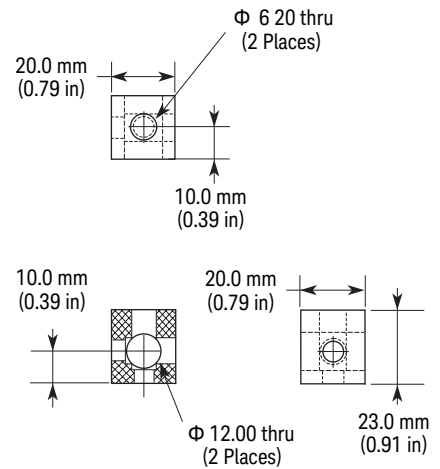

Keysight 10769B Turning Mirror (Base Block Only)

Keysight 55290A Angular Position Measurement Kit

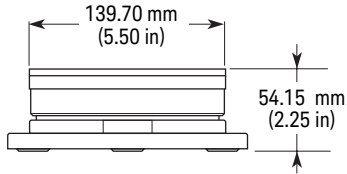
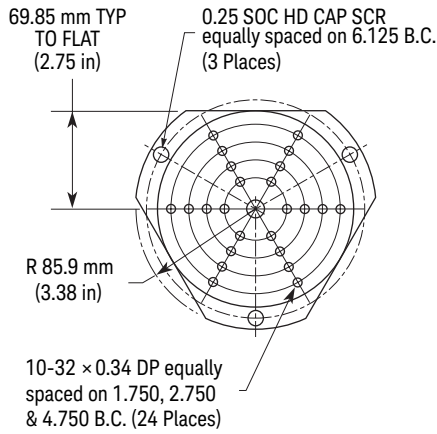

Rotary Indexing Table

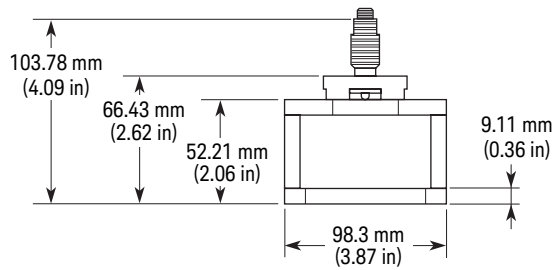
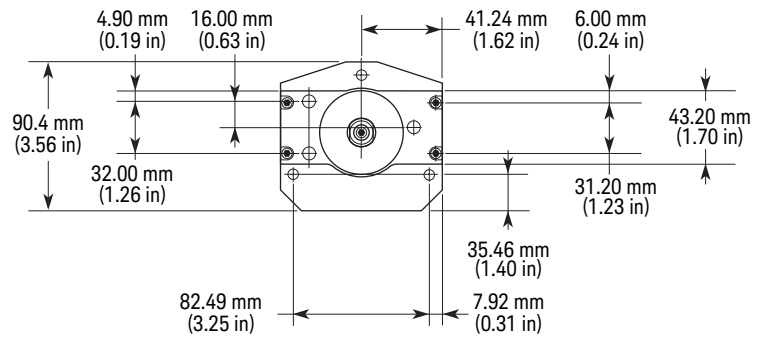

Fixture, Angle Position Measurement

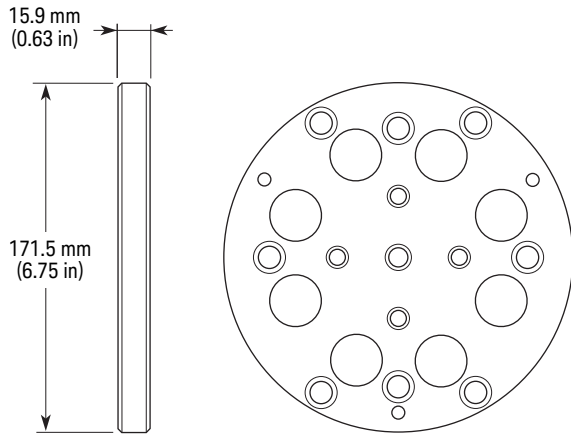

Adapter Plate

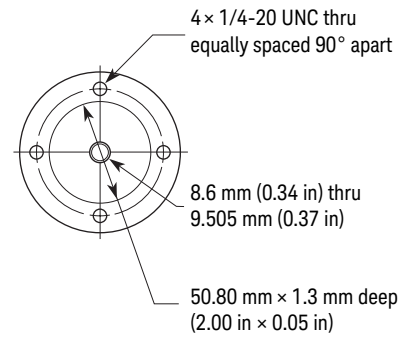
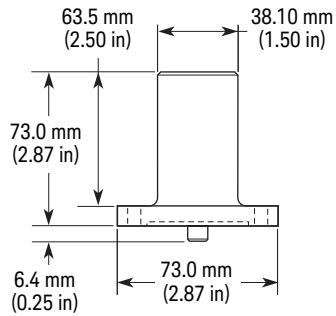

Flanged Shaft

Keysight 55290A Angular Position Measurement Kit

Adapter Plate

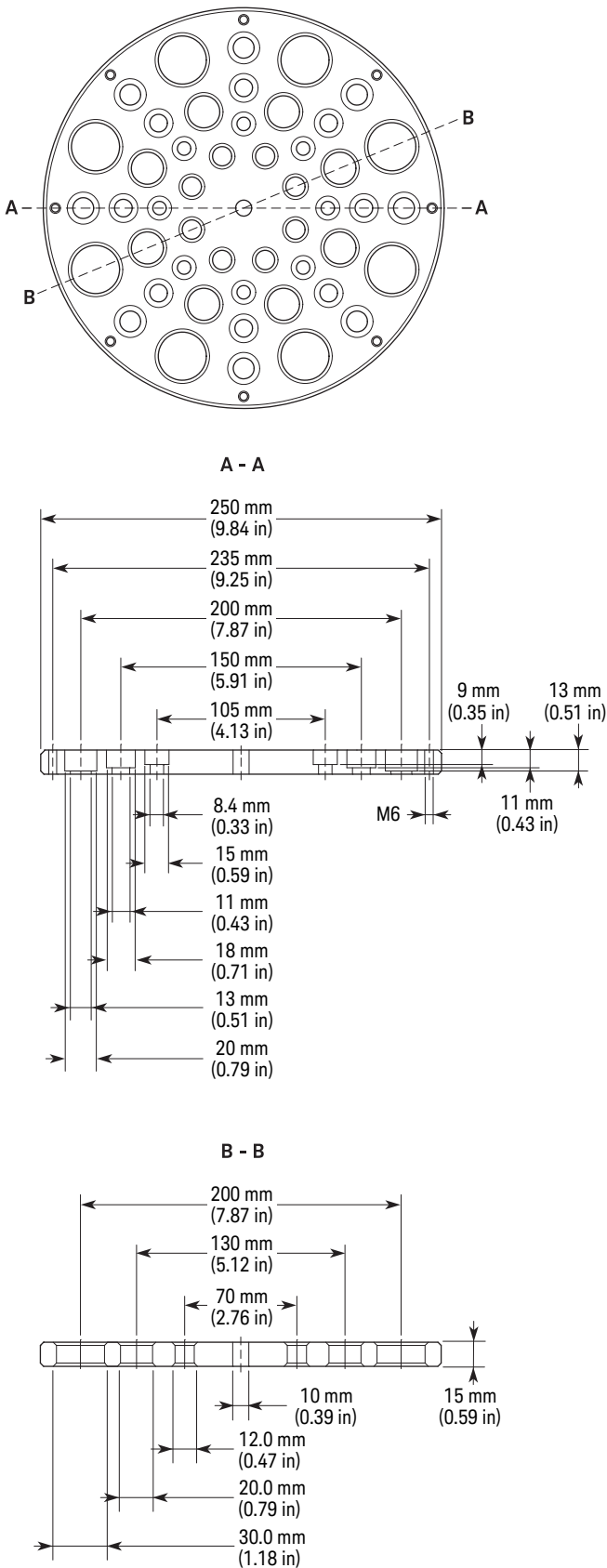

Flanged Shaft

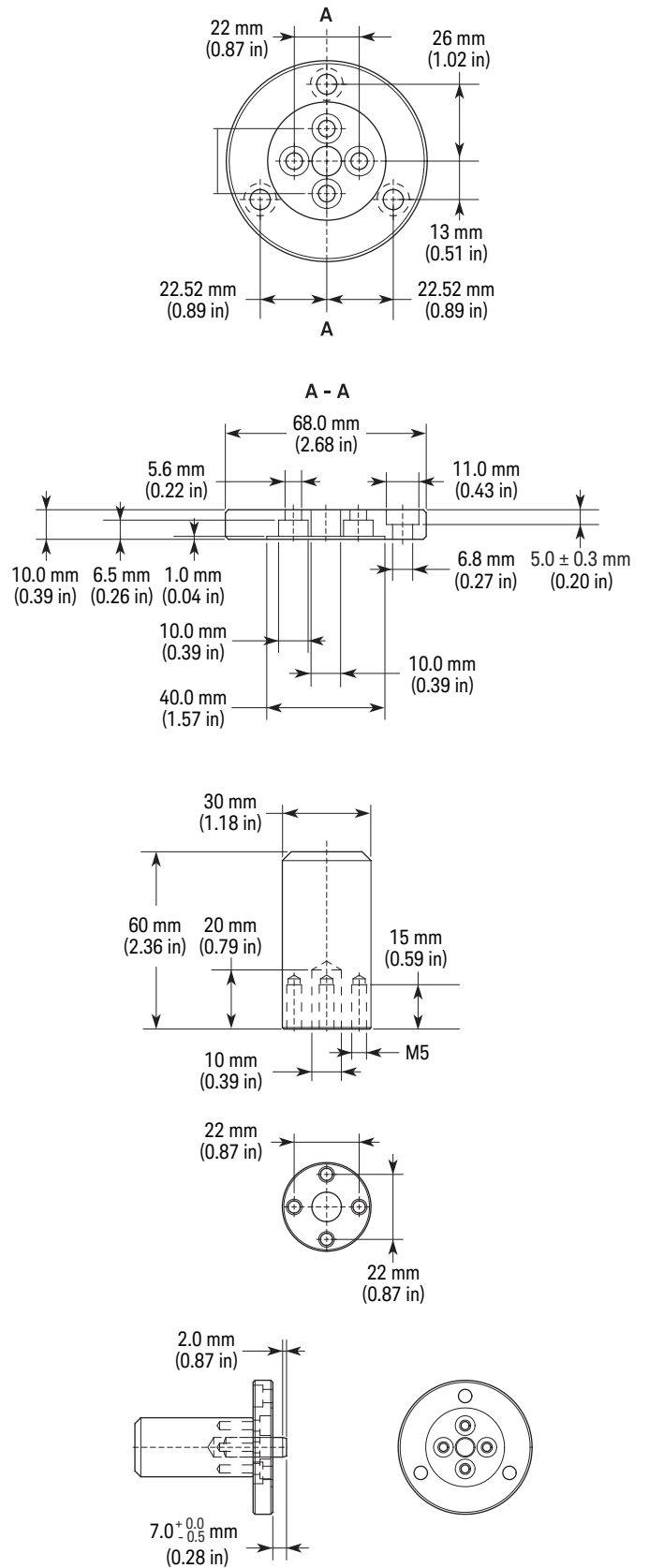

myKeysight

myKeysight

www.keysight.com/find/mykeysight

A personalized view into the information most relevant to you.



www.axistandard.org

AdvancedTCA® Extensions for Instrumentation and Test (AXIe) is an open standard that extends the AdvancedTCA for general purpose and semiconductor test. Keysight is a founding member of the AXIe consortium. ATCA®, AdvancedTCA®, and the ATCA logo are registered US trademarks of the PCI Industrial Computer Manufacturers Group.



www.lxistandard.org

LAN eXtensions for Instruments puts the power of Ethernet and the Web inside your test systems. Keysight is a founding member of the LXI consortium.



www.pxisa.org

PCI eXtensions for Instrumentation (PXI) modular instrumentation delivers a rugged, PC-based high-performance measurement and automation system.

Three-Year Warranty

www.keysight.com/find/ThreeYearWarranty

Keysight's commitment to superior product quality and lower total cost of ownership. The only test and measurement company with three-year warranty standard on all instruments, worldwide.



Keysight Assurance Plans

www.keysight.com/find/AssurancePlans

Up to five years of protection and no budgetary surprises to ensure your instruments are operating to specification so you can rely on accurate measurements.



www.keysight.com/quality

Keysight Technologies, Inc.
DEKRA Certified ISO 9001:2008
Quality Management System



Keysight Channel Partners

www.keysight.com/find/channelpartners

Get the best of both worlds: Keysight's measurement expertise and product breadth, combined with channel partner convenience.

www.keysight.com/find/machinetoolcalibration

For more information on Keysight Technologies' products, applications or services, please contact your local Keysight office. The complete list is available at: www.keysight.com/find/contactus

Americas

Canada	(877) 894 4414
Brazil	55 11 3351 7010
Mexico	001 800 254 2440
United States	(800) 829 4444

Asia Pacific

Australia	1 800 629 485
China	800 810 0189
Hong Kong	800 938 693
India	1 800 112 929
Japan	0120 (421) 345
Korea	080 769 0800
Malaysia	1 800 888 848
Singapore	1 800 375 8100
Taiwan	0800 047 866
Other AP Countries	(65) 6375 8100

Europe & Middle East

Austria	0800 001122
Belgium	0800 58580
Finland	0800 523252
France	0805 980333
Germany	0800 6270999
Ireland	1800 832700
Israel	1 809 343051
Italy	800 599100
Luxembourg	+32 800 58580
Netherlands	0800 0233200
Russia	8800 5009286
Spain	0800 000154
Sweden	0200 882255
Switzerland	0800 805353
	Opt. 1 (DE)
	Opt. 2 (FR)
	Opt. 3 (IT)
United Kingdom	0800 0260637

For other unlisted countries:
www.keysight.com/find/contactus
(SM-03-22-16)

